

LED LOD-LHB EL Linear High Bay Light Series

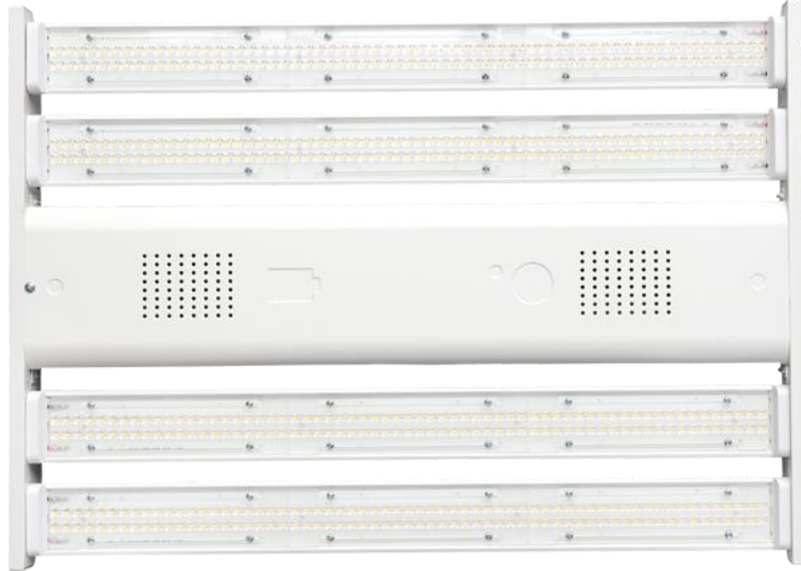

FEATURES

- IP40 rated
- Easy installation and maintenance
- 100,000 hours lifetime

SUITABLE APPLICATIONS

- Warehouses
- Stadiums
- Factories
- Supermarkets
- Logistic Centers
- Exhibition Halls

CONSTRUCTION:

Fixture body and endcaps are fabricated from aluminum for maximum rigidity. Lightweight aluminum heat sink designed to perform naturally convective cooling.

OPTICAL SYSTEM:

Samsung 2835 LED chips. Frosted lens. 120° beam angle options.

WARRANTY:

5-year limited warranty. Actual performance may differ as a result of end-user environment and application.

ELECTRICAL:

Available as 120-277V input. -20°C to 40°C, -4°F to 104°F

INSTALLATION & MOUNTING:

Hanging mount, surface mount or pendant mount.

CONTROLS & DIMMING:

1-10V dimming comes standard. Suitable for use with LED dimmers. Motion sensor option available.

Special Order:

- Other CCTs
- Frosted lens



MODEL NUMBER – 5,000K	WATTAGE	LUMENS	EFFICACY	CRI	POWER FACTOR	THD	REPLACES
LOD-LHB161W-50K-EL-FC-[Blank,EM]-[Blank,MS]	161W	22,540LM	140LM/W	80	0.9	20%	250W HID

DLC Product ID:

- LOD-LHB161W-50K-EL-FC – PLFF5H1SSMP3

Series	Wattage	CCT Options	Dimming Options	Optional
LOD-LHB EL	161W	5,000K	0-10V Dimming Integrated Motion Sensor	MS - Motion Sensor EM – Emergency Battery

MEASUREMENTS

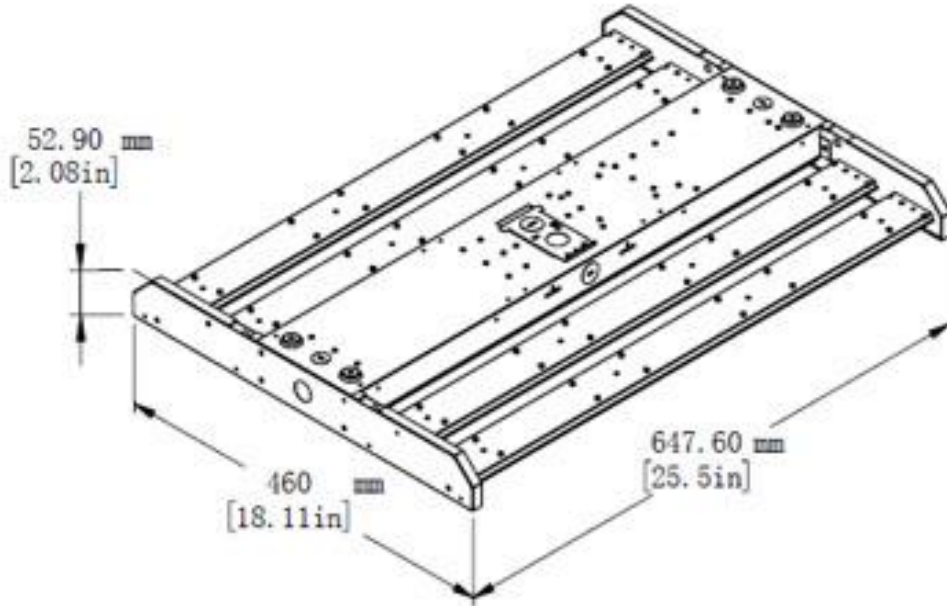

MODEL	QUANTITY	WEIGHT	UPC CODE
LOD-LHB161W-50K-EL-FC-[Blank,EM]-[Blank,MS]	1	lbs	00815586024056

MOUNTING OPTIONS



Pendant Mount



Chain & Hook

OPTIONAL ACCESSORIES



Microwave Motion Sensor
HB006



Remote Control
LOC-GDHB-HD05R



Emergency Driver
LOC-EMDR-25WHV