

Date: _____ Location: _____
 Product: _____ Project: _____
 Quantity: _____ Catalog #: _____

LED Linear High Bay Light



FEATURES

- IP54 rated
- Easy installation and maintenance
- 50,000 hours lifetime

SUITABLE APPLICATIONS

- Warehouses
- Stadiums
- Factories
- Supermarkets
- Logistic Centers
- Exhibition Halls

CONSTRUCTION:

Aluminum body.

OPTICAL SYSTEM:

40° or 90° beam angle options.

WARRANTY:

5-year limited warranty. Actual performance may differ as a result of end-user environment and application.

ELECTRICAL:

Available as 120-277V input. -20°C to 40°C, -4°F to 104°F

INSTALLATION & MOUNTING:

Suspended mounting or ceiling mounting.

CONTROLS & DIMMING:

Dimmable



MODEL NUMBER – 5,000K	WATTAGE	LUMENS	EFFICACY	CRI	POWER FACTOR	THD	REPLACES
LOD-LNHB-LHBP50W-50K	50W	6,942.6LM	139.72LM/W	72.8	0.9	21.96%	125W HID

MEASUREMENTS

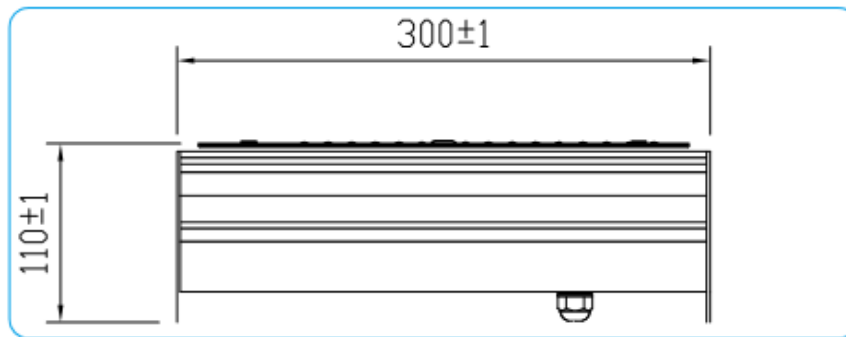

50W

MODEL	QUANTITY	UPC CODE
LOD-LNHB-LHBP50W-50K	1	00815586023431