

## LED 4FT LOD-LHB 160W Linear High Bay Light



### FEATURES

- IP54 rated
- Easy installation and maintenance
- 100,000 hours lifetime

### SUITABLE APPLICATIONS

- Warehouses
- Stadiums
- Factories
- Supermarkets
- Logistic Centers
- Exhibition Halls

#### CONSTRUCTION:

PMMA lens material. Steel and aluminum body.

#### OPTICAL SYSTEM:

Samsung 2835 LED chips. Frosted lens. 120° beam angle options.

#### WARRANTY:

5-year limited warranty. Actual performance may differ as a result of end-user environment and application.

#### ELECTRICAL:

Available as 120-277V input. -20°C to 40°C, -4°F to 104°F

#### INSTALLATION & MOUNTING:

Hanging chain or pendant mount.

#### CONTROLS & DIMMING:

0-10V dimming comes standard.

#### Special Order:

- Other CCTs



MODEL NUMBER – 5,000K	WATTAGE	LUMENS	EFFICACY	CRI	POWER FACTOR	THD	REPLACES
LOD-LHB4FT160W-50K	160W	22,379LM	139LM/W	80	0.9	20%	400W HID

#### DLC Product ID:

- LOD-LHB4FT160W-50K – S-85IVRS

Series	Wattage	CCT Options	Dimming Options
LOD-LHB	160W	5,000K	0-10V Dimming

## MEASUREMENTS

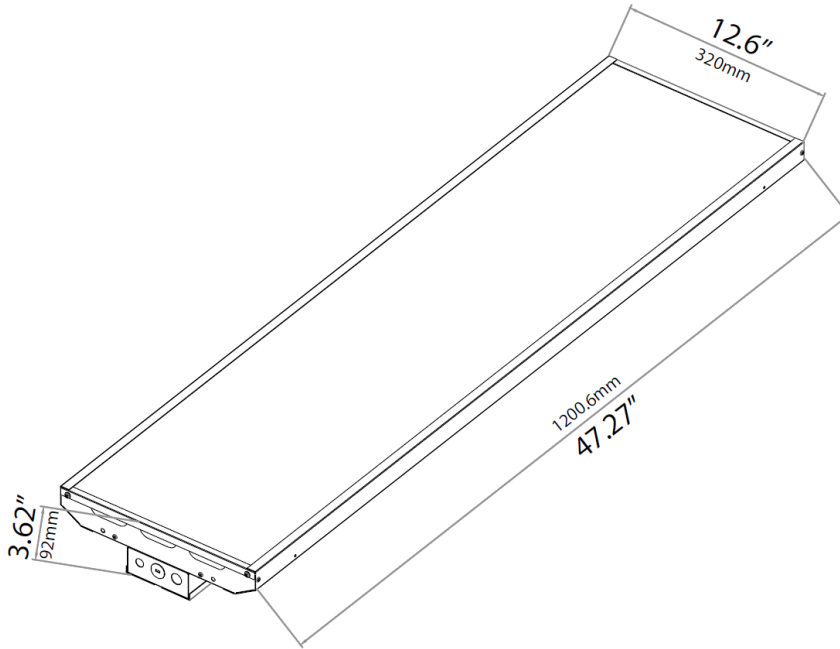

MODEL	QUANTITY	WEIGHT	UPC CODE
LOD-LHB4FT160W-50K	1	18.25 lbs	00815586027897

## MOUNTING OPTIONS



Pendant Mount



Chain & Hook

## OPTIONAL ACCESSORIES



Non-Dim Motion Sensor  
LOD-BRI819P-B-O



Motion Sensor  
LOD-BRI819P-B-D



Remote Control  
LOC-RC100



Emergency Driver  
LOC-EMDR-25WHV