

Date: \_\_\_\_\_ Location: \_\_\_\_\_  
 Product: \_\_\_\_\_ Project: \_\_\_\_\_  
 Quantity: \_\_\_\_\_ Catalog #: \_\_\_\_\_

## LED Modular Wall Pack Light Series



40W or 60W



90W or 120W

### FEATURES

- IP65 rated
- Rust and corrosion proof
- 50,000 hours lifetime

### SUITABLE APPLICATIONS

- Area lighting
- Parking decks
- Auto dealerships
- High masts
- Housing complexes
- Shopping malls
- Sporting complexes
- Parks and Recreational areas
- Municipal lots

#### CONSTRUCTION:

Heavy duty die-cast aluminum housing. High quality tempered glass optics. Polyester powder-coated finish. Stabilized to extreme climate changes without cracking or peeling.

#### OPTICAL SYSTEM:

Philips Lumileds 3030 LED chips. 70° x 135° beam angle. High quality tempered glass optics.

#### WARRANTY:

5-year limited warranty. Actual performance may differ as a result of end-user environment and application.

#### ELECTRICAL:

Available as 100-277V input. -30°C to 45°C, -22°F to 113°F

#### INSTALLATION & MOUNTING:

Wall mount.

#### DIMMING:

Non-dimming.



MODEL NUMBER – 5,000K	WATTAGE	LUMENS	EFFICACY	CRI	POWER FACTOR	THD	REPLACES
LOD-MSL-WP40W-50K (G)	40W	5,418.86LM	144.97LM/W	72.6	0.9	7.48%	100W HID
LOD-MSL-WP60W-50K (G)	60W	6,806.42LM	126.51LM/W	73.2	0.943	4.84%	150W HID
LOD-MSL-WP90W-50K (G)	90W	13,050LM	145LM/W	70	0.95	15%	200W HID
LOD-MSL-WP120W-50K (G)	120W	15,000LM	125LM/W	70	0.9	20%	250W HID

Series	Wattage	Color Temperature
LOD-MSL-WP	40W 60W 90W 120W	5000K

## MEASUREMENTS

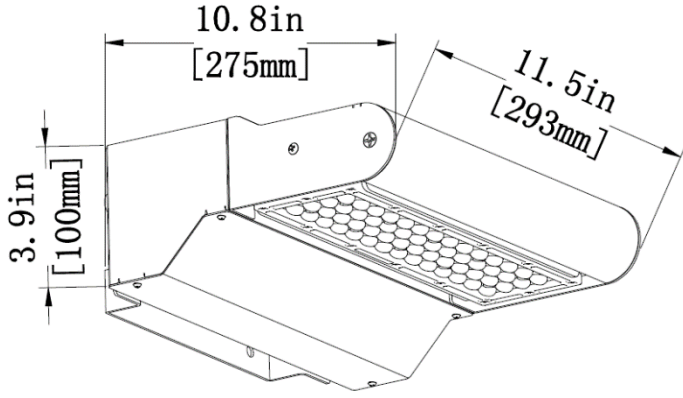

**40W or 60W**

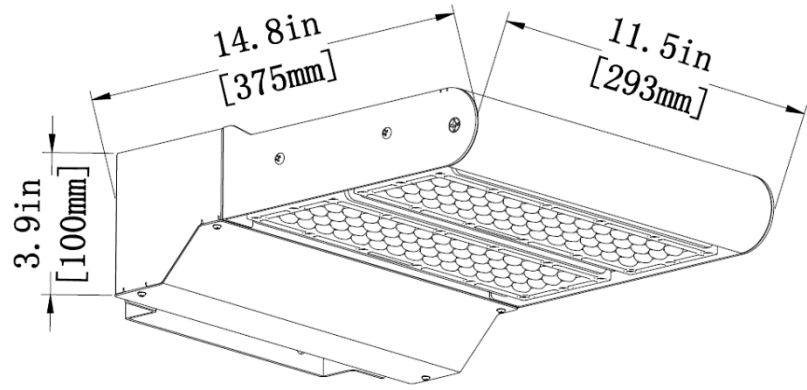

**90W or 120W**

MODEL	QUANTITY	WEIGHT	UPC CODE
LOD-MSL-WP40W-50K (G)	1	8.82 lbs	00815586028474
LOD-MSL-WP60W-50K (G)	1	8.82 lbs	00815586028481
LOD-MSL-WP90W-50K (G)	1	11.02 lbs	00815586028498
LOD-MSL-WP120W-50K (G)	1	11.02 lbs	00815586028504