

LED LOC-FGHB High Bay Family Series (200W model with microwave sensor pre-installed)



150W



Motion sensor optional

200W with Microwave Sensor

CONSTRUCTION:

Die-cast aluminum housing. Clear tempered glass lens.

OPTICAL SYSTEM:

Philips LED chips. 115° beam angle option.

WARRANTY:

5-year limited warranty. Actual performance may differ as a result of end-user environment and application.

ELECTRICAL:

Available as 100-277V input.

-40°C to 45°C, -40°F to 113°F

120-347V or 277-480V special order options.

-40°C to 70°C, -40°F to 158°F special order option.

INSTALLATION & MOUNTING:

O-hook or pendant mount.

DIMMING:

0-10V dimming

FEATURES

- IP69K rated
- Corrosion resistant
- Optional microwave sensor can be installed in the middle of the lens
- Safety cable included
- Easy installation and maintenance
- 50,000 hours lifetime
- NSF rated for splash zone and non-food zone

SUITABLE APPLICATIONS

- Chemical plants
- Steel manufacturing plants
- Logistics warehouses
- Breweries
- Food processing spaces
- Pharmaceutical Factories
- Farm / Animal Buildings
- Car Washes
- Fresh Shops
- Supermarkets

DLC Product ID:

- LOC-FGHB-150W50K-DLV – PB1FX3L4
- LOC-FGHB-200W50K-DLV – P9RYCMNC

NSF Model Number:

- LOC-FGHB-150W50K-DLV
- LOC-FGHB-200W50K-DLV

MOUNTING OPTIONS:

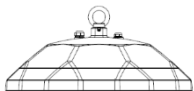

O-Hook

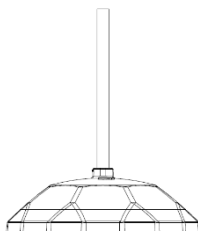

Pendant

OPTIONAL ACCESSORIES:



Integrated Microwave Sensor



Remote Control
LOC-GDHB



Emergency Battery
LOC-HBEMDR-25WHV

Note: If you would like to add a motion sensor, please inform your sales representative **at the time of placing an order**. Needs to be installed at factory.



LOC-FGHB-150W50K-DLV-B

WATTAGE	CCT	LUMENS	EFFICACY	VOLTAGE	CRI	POWER FACTOR	THD	REPLACES
150W	5000K	21,900LM	146lm/W	120-277V	80	0.9	15%	

LOC-FGHB-200W50K-DLV-MSB (WITH MICROWAVE SENSOR)

WATTAGE	CCT SELECTABLE	LUMENS	EFFICACY	VOLTAGE	CRI	POWER FACTOR	THD	REPLACES
200W	5000K	29,200LM	146lm/W	120-277V	80	0.9	15%	

MEASUREMENTS

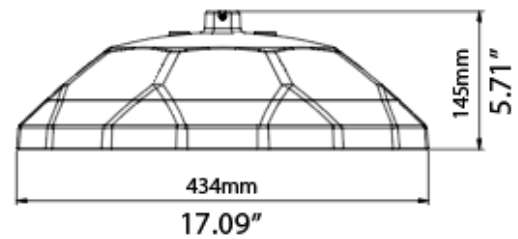
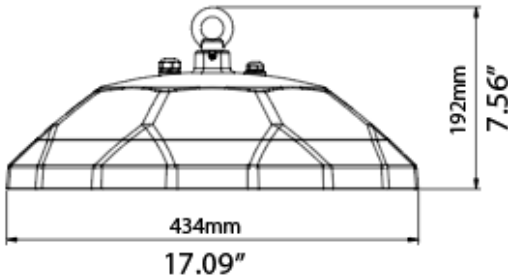
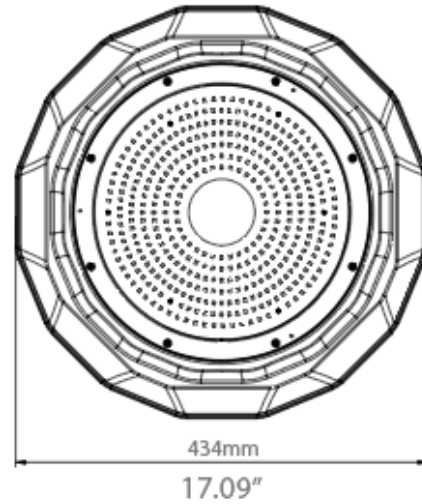
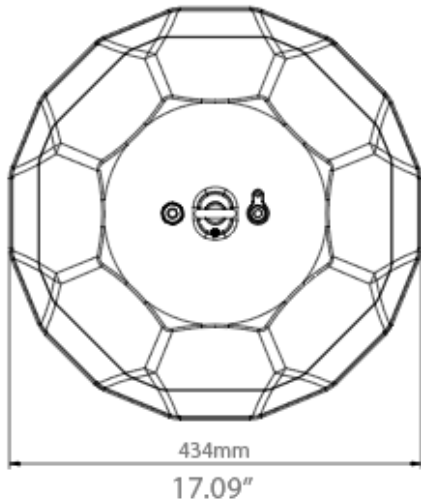

MODEL	QUANTITY	WEIGHT	UPC CODE
LOC-FGHB-150W50K-DLV-[MS,NS]B	1	13.2 lbs	00810050940610
LOC-FGHB-200W50K-DLV-[MS,NS]B	1	16.5 lbs	00810050940627