

LED 2 Foot Multi Wattage Linear High Bay



110W / 135W / 160W

CONSTRUCTION:

Die formed galvanized steel, white paint.
Isolated driver with wide voltage input option.
Frosted PMMA lens. (Clear lens special order)

OPTICAL SYSTEM:

Lumileds 2835 LED chips. 120° beam angle options.

WARRANTY:

5-year limited warranty. Actual performance may differ as a result of end-user environment and application.

ELECTRICAL:

Available as 120-277V input.

-20°C to 40°C, -4°F to 104°F

INSTALLATION & MOUNTING:

Hanging hook or pendant mount.

CONTROLS & DIMMING:

0-10V dimming comes standard. Suitable for use with LED dimmers.

FEATURES

- Default Wattage:
 - 160W
- IP40 rated
- DC 12V auxiliary
- Easy installation and maintenance
- 50,000 hours lifetime

SUITABLE APPLICATIONS

- Warehouses
- Factories
- Supermarkets
- Logistic Centers
- Exhibition Halls

MOUNTING OPTIONS:



Pendant Mount



Chain & Hook

DLC Product ID:

- LOC-2FTLHB-MW(110/135/160)50KD – S-J5021Y

TAA Compliant Option Available.

Contact your Sales Representative for more information.



OPTIONAL ACCESSORIES:



Non-Dim Motion Sensor
LOD-BR1819P-B-O



Motion Sensor
LOD-BR1819P-B-D



Remote Control
LOD-RC-100



Emergency Driver
LOC-EMDR-25WHV

LOC-2FTLHB-MW(110/135/160)50KD

WATTAGE SELECTABLE	CCT	LUMENS	EFFICACY	VOLTAGE	CRI	POWER FACTOR	THD	REPLACES
110W	5000K	14,850LM	135lm/W	120-277V	80	0.9	20%	400W HID
135W	5000K	18,225LM	135lm/W	120-277V	80	0.9	20%	400W HID
160W	5000K	21,600LM	135lm/W	120-277V	80	0.9	20%	400W HID

MEASUREMENTS

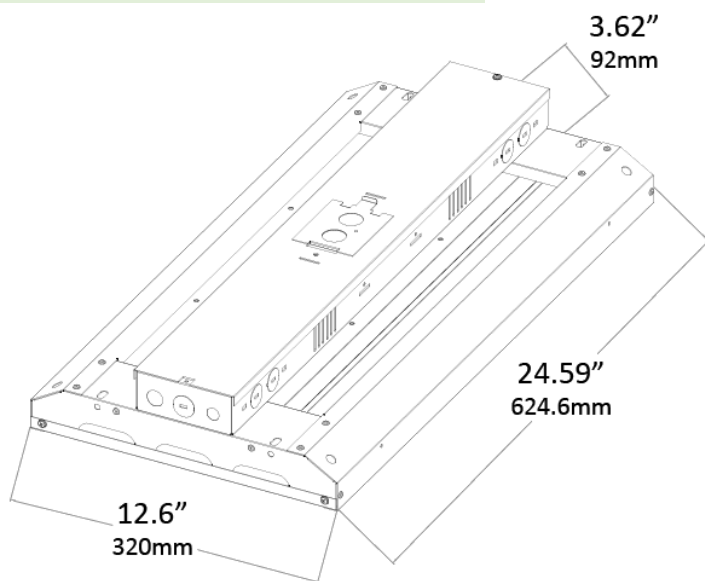

MODEL	QTY	NET WEIGHT	MASTER CARTON SIZE	GROSS WEIGHT	PCS CTN	UPC CODE
LOC-2FTLHB-MW(110/135/160)50KD	1	10.8lbs	26.5" x 14" x 4.25"	12.05lbs	1	00810050943680

WATTAGE SELECTABLE

